

Column Protectors

Highly versatile Column Protectors provide strong protection for vulnerable columns, exposed pipework, etc. against damage by motorised transport.

- ‘One way’ assembly for easy installation
- Strong steel construction
- Isolates column from impact shock
- Highly visible versions

Applications: Warehouses, logistic depots, street posts and trees, factories, public buildings, etc

Specifications:

Dimensions: H x W x D
 600 x 520 x 520mm (Type 7613-7614)
 600 x 620 x 620mm (Type 7615-7616)
 600 x 720 x 720mm (Type 7617-7618)

Tube diameter: 60/48mm
 Wall thickness: 2mm
 Material: steel
 Anchor plates: 4 x 160 x 70 x 10mm (drilled 2 holes per plate)
 Finish: Hot dip galvanised or hot dip galvanised & power coated yellow with black bands

7613



7614

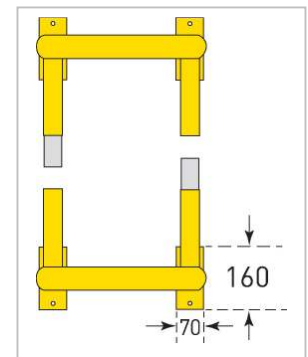
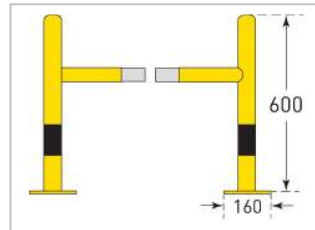

Description	Fixing bolts required per protector	Dimension (mm) H x W x D	Finish	Delivery weight	Type
	8	600 x 520 x 520 Internal: 400 x 400	Hot dip galvanised	14.5kg	7613
			Hot dip galvanised & powder coated	14.5kg	7614
		600 x 620 x 620 Internal: 500 x 500	Hot dip galvanised	16kg	7615
			Hot dip galvanised & powder coated	16kg	7616
		600 x 720 x 720 Internal: 600 x 600	Hot dip galvanised	17.5kg	7617
			Hot dip galvanised & powder coated	17.5kg	7618
Rawl plug (pack of 8) 	-	100 x 12	-	-	5798
Throughbolt anchor (pack of 8) 	-	100 x 12	-	-	5799

Please note: all bolts to be ordered at same time as the bars to avoid extra carriage costs